FnIO G-Series

GT-5211, 5212, 5221, 5231, 5232

GT-5211 (1 Channel, RS-232 Serial Interface, RTS/CTS)

GT-5212 (2 Channels, RS-232 Serial Interface)

GT-5221 (1 Channel, RS-422 Serial Interface)

GT-5231 (1 Channel, RS-485 Serial Interface)

GT-5232 (2 Channels, RS-485 Serial Interface)

Specification

History

REV.	PAGES	REMARKS	DATE	Editor
1	36		Aug 25, 2016	HS KIM
1.01	6	Power Dissipation retest	Nov 01, 2016	HS KIM
1.02		Edit Typo	Apr 27, 2017	HS KIM
1.03	23~37	Edit Typo	Mar 14, 2018	HS KIM
1.04		Release	Apr 21, 2020	Soyeong, Park
1.05		Edit Typo	Nov 26, 2020	HS KIM
1.06		Edit Typo	Jan 04, 2021	HS KIM
1.07	38~41	Add XML change method	Jan 18, 2021	HS KIM

Table of Contents

History.....	2
Table of Contents.....	3
1.Environment Specification.....	5
2.GT-52xx (Serial).....	6
2.1.GT-52xx(Serial) Specification.....	6
2.2.GT-52xx(Serial) Wiring Diagram.....	7
2.2.1.GT-5211(RS232/1 Channel).....	7
2.3.GT-5211 LED Indicator.....	8
2.3.1.LED Indicator.....	8
2.3.2.Channel Status LED.....	8
2.4.GT-5212(RS232/2 Channels).....	9
2.5.GT-5212 LED Indicator.....	10
2.5.1.LED Indicator.....	10
2.5.2.Channel Status LED.....	10
2.6.GT-5221(RS422/1 Channel).....	11
2.7.GT-5221 LED Indicator.....	12
2.7.1.LED Indicator.....	12
2.7.2.Channel Status LED.....	12
2.8.GT-5231(RS485/1 Channel).....	13
2.9.GT-5231 LED Indicator.....	14
2.9.1.LED Indicator.....	14
2.9.2.Channel Status LED.....	14
2.10.GT-5232(RS485/2 Channels).....	15
2.11.GT-5232 LED Indicator.....	16
2.11.1.LED Indicator.....	16
2.11.2.Channel Status LED.....	16
2.12.Configuration and Operation Function	17
2.12.1.GT-52xx(Series) Mapping data into the image table	17
2.13.Configuration Parameter Data	20
2.13.1.1 Chnnel Module Parameter Data(GT-5211)	20
2.13.2.1 Chnnel Module Parameter Data(GT-5221, 5231)	21
2.13.3.2 Chnnels Module Parameter Data(GT-5212, 5232)	22
2.14.Example.....	23
2.14.1.Example of Transmitting data	23

Specification

2.14.2.Example of Receiving data.....	25
2.14.3.Example of Transmitting data and Receiving data.....	28
2.14.4.TPR and TPA Example.....	31
2.14.5.GT-5211, 5221(1ch) RxD Buffer data Overrun Check.....	36
2.14.6.How to change I/O Data Size in XML file(I/O Guide Pro).....	38
2.14.7.How to change I/O Data Size in XML file(CODESYS).....	41

Specification

1. Environment Specification

Environmental Specification	
Operation Temperature	-40°C ~70°C
UL Temperature	-20°C ~60°C
Non-Operating Temperature	-40°C ~85°C
Relative Humidity	5% ~ 90% Non-condensing
Mounting	DIN rail
General Specification	
Shock Operating	IEC 60068-2-27 : 2008/15g, 11ms
Vibration Resistance	Based on IEC 60068-2-6 DNVGL-CG-0039 : Vibration Class B, 4g
Industrial Emissions	EN61000-6-4/All : 2011
Industrial Immunity	EN61000-6-2 : 2005
Installation Position	Vertical and horizontal installation is available
Product Certifications	CE, UL, FCC

Specification

2. GT-52xx (Serial)

2.1. GT-52xx(Serial) Specification

Items	GT-5211	GT-5212	GT-5221	GT-5231	GT-5232
Specification					
Transfer Channels	TxD, RxD, Full Duplex			TxD, RxD, Half Duplex	
Transfer Rate	1200bps~115200bps				
Data Bit	8bit				
Parity Bit	None, Odd, Even(*Default : None)				
Stop Bit	1bit, 2bit (*Default : 1bit)				
Flow Control	RTS,CTS			-	
Bit Distortion	<1.6%			-	
Connection	10 RTB				
Cable Type	Shield Cable Recommended.				
Cable Length	Max.15m		1km twisted pair		
Low Signal Voltage	-18V ~ -3V		-		
High Signal Voltage	3V ~ 18V		-		
Data Buffer	IO User data 14 bytes (* Default) @Max. 61 Bytes	IO User data 12 bytes (* Default) @Max. 58 Bytes	IO User data 14 bytes (* Default) @Max. 61 Bytes	IO User data 12 bytes (* Default) @Max. 58 Bytes	
	IO size changed Max. 63 bytes	IO size changed Max. 62 bytes	IO size changed Max. 63 bytes		IO size changed Max. 62 bytes
	Control/Status 1 byte, Rx/Tx Length 1 byte	Control/Status 2 bytes Rx/Tx Length 2 bytes	Control/Status 1 byte, Rx/Tx Length 1 byte		Control/Status 2 bytes Rx/Tx Length 2 bytes
RXD Buffer	1024bytes				
TXD Buffer	1024bytes				
Line Impedance	-		120Ω		
Input Image Size	16 bytes (*Default) @ Max. 63 bytes	16 bytes (*Default) @ Max. 62 bytes	16 bytes (*Default) @ Max. 63 bytes		16 bytes (*Default) @ Max. 62 bytes
Output Image Size	16 bytes (*Default) @ Max. 63 bytes	16 bytes (*Default) @ Max. 62 bytes	16 bytes (*Default) @ Max. 63 bytes		16 bytes (*Default) @ Max. 62 bytes
General Specification					
Power dissipation	Max. 85mA @ 5Vdc				
Isolation	I/O to Logic : Isolation Logic to Field power : Isolation (Not used) Logic to System Power : Non-isolation				
UL field power	Supply Voltage : 24Vdc nominal, Class 2				
Field power	Not used Field power bypass to next expansion module				
Wiring	I/O Cable Max. 2.0mm ² (AWG 14)				
Torque	0.8Nm (7lb-in)				
Weight	57g				
Module size	12mm x 99mm x 70mm				
Environment condition	Refer to 'Environment Specification'				

Specification

2.2. GT-52xx(Serial) Wiring Diagram

2.2.1. GT-5211(RS232/1 Channel)

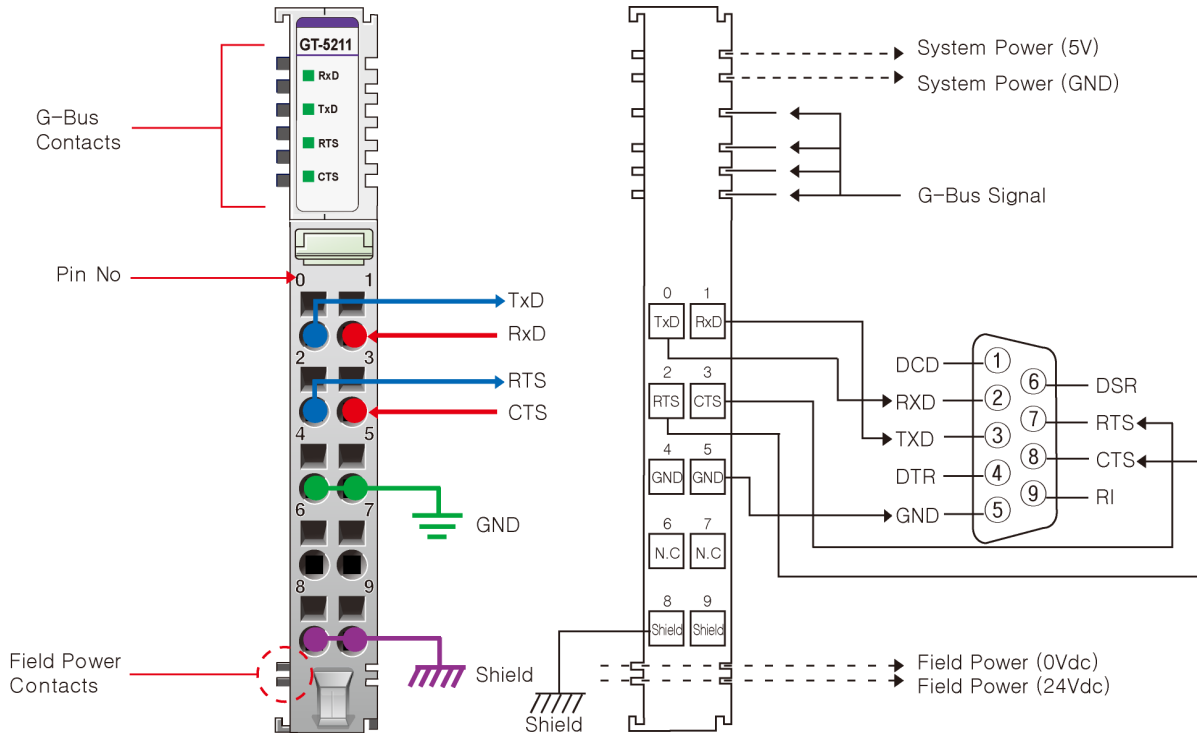

Pin No.	Signal Description	Signal Description	Pin No.
0	TxD	RxD	1
2	RTS	CTS	3
4	Common(GND)	Common(GND)	5
6	N.C	N.C	7
8	Shield	Shield	9

2.3. GT-5211 LED Indicator

2.3.1. LED Indicator

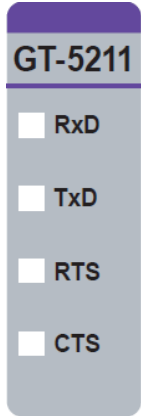

LED No.	LED Function / Description	LED Color
RxD	Received Data	Green
TxD	Transmit Data	Green
RTS	Request-to-send	Green
CTS	Clear-to-send	Green

2.3.2. Channel Status LED

LED	Color	Status
RxD	GREEN	Received Data
TxD	GREEN	Transmit Data
RTS	GREEN	Request-to-send
CTS	GREEN	Clear-to-send

Specification

2.4. GT-5212(RS232/2 Channels)

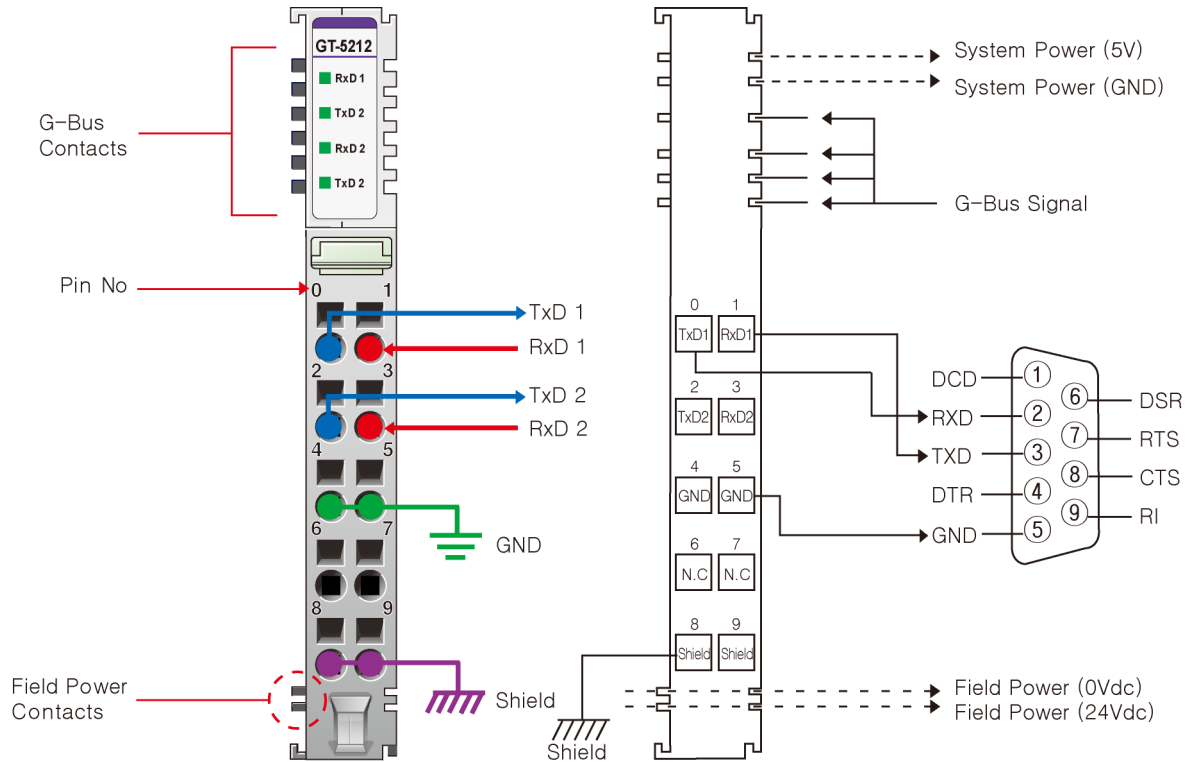

Pin No.	Signal Description	Signal Description	Pin No.
0	TxD1	RxD1	1
2	TxD2	RxD2	3
4	Common(GND)	Common(GND)	5
6	N.C	N.C	7
8	Shield	Shield	9

2.5. GT-5212 LED Indicator

2.5.1. LED Indicator



LED No.	LED Function / Description	LED Color
RxD1	Received Data 1	Green
TxD1	Transmit Data 1	Green
RxD2	Received Data 2	Green
TxD2	Transmit Data 2	Green

2.5.2. Channel Status LED

LED	Color	Status
RxD1	GREEN	Received Data 1
TxD1	GREEN	Transmit Data 1
RxD2	GREEN	Received Data 2
TxD2	GREEN	Transmit Data 2

Specification

2.6. GT-5221(RS422/1 Channel)

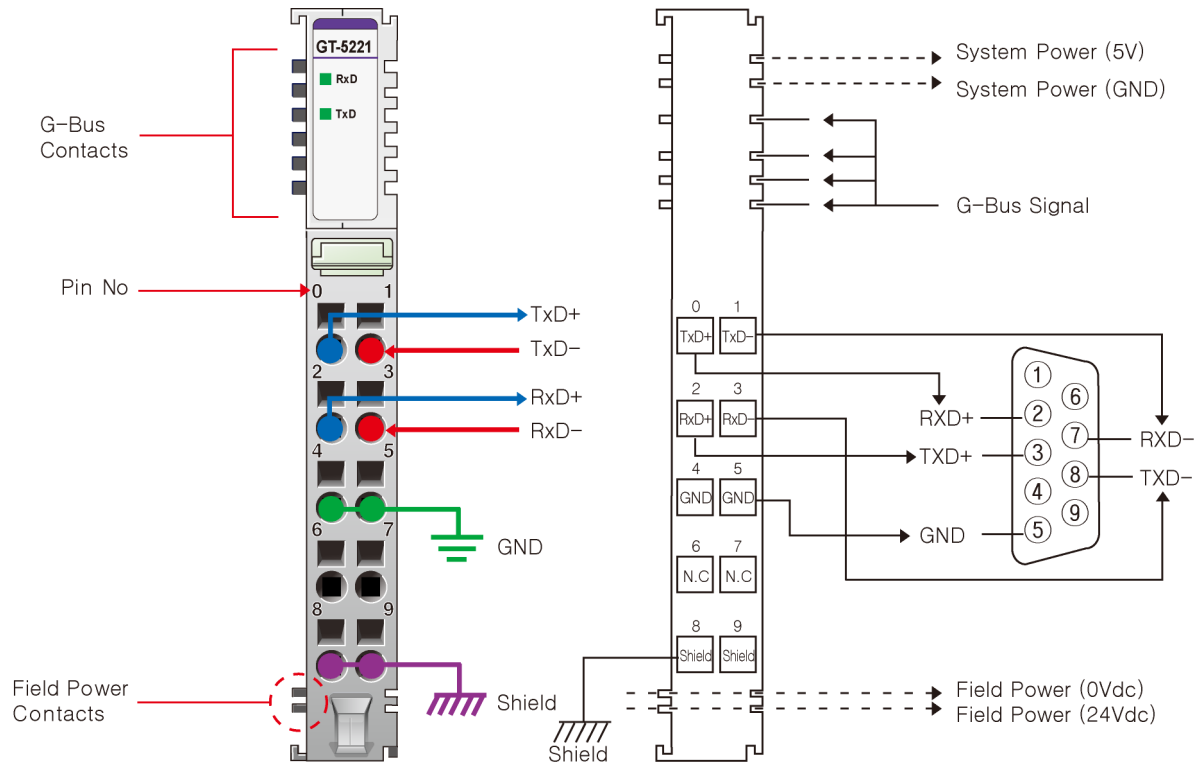

Pin No.	Signal Description	Signal Description	Pin No.
0	TxD+	TxD-	1
2	RxD+	RxD-	3
4	Common(GND)	Common(GND)	5
6	N.C	N.C	7
8	Shield	Shield	9

2.7. GT-5221 LED Indicator

2.7.1. LED Indicator



LED No.	LED Function / Description	LED Color
RxD	Received Data	Green
TxD	Transmit Data	Green

2.7.2. Channel Status LED

LED	Color	Status
RxD	GREEN	Received Data
TxD	GREEN	Transmit Data

2.8. GT-5231(RS485/1 Channel)

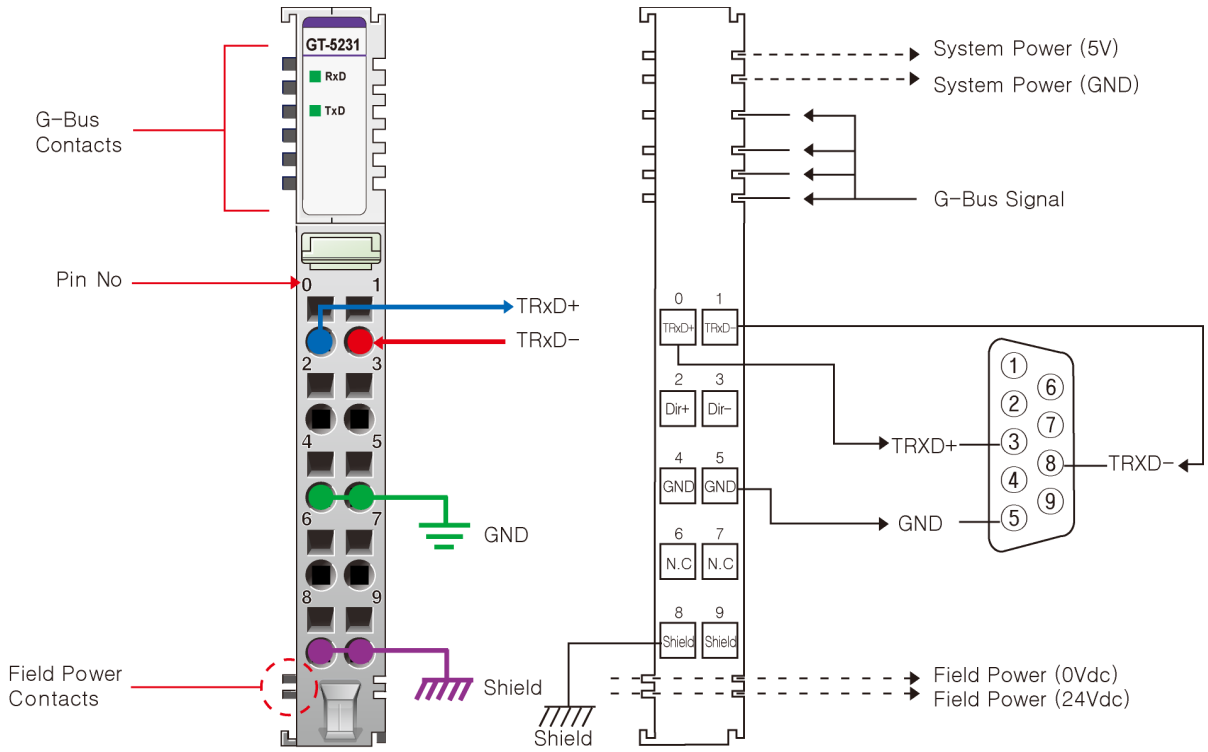

Pin No.	Signal Description	Signal Description	Pin No.
0	RS485+	RS485-	1
2	DIR+	DIR-	3
4	Common(GND)	Common(GND)	5
6	N.C	N.C	7
8	Shield	Shield	9

2.9. GT-5231 LED Indicator

2.9.1. LED Indicator

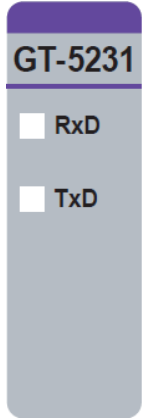

LED No.	LED Function / Description	LED Color
RxD	Received Data	Green
TxD	Transmit Data	Green

2.9.2. Channel Status LED

LED	Color	Status
RxD	GREEN	Received Data
TxD	GREEN	Transmit Data

2.10. GT-5232(RS485/2 Channels)

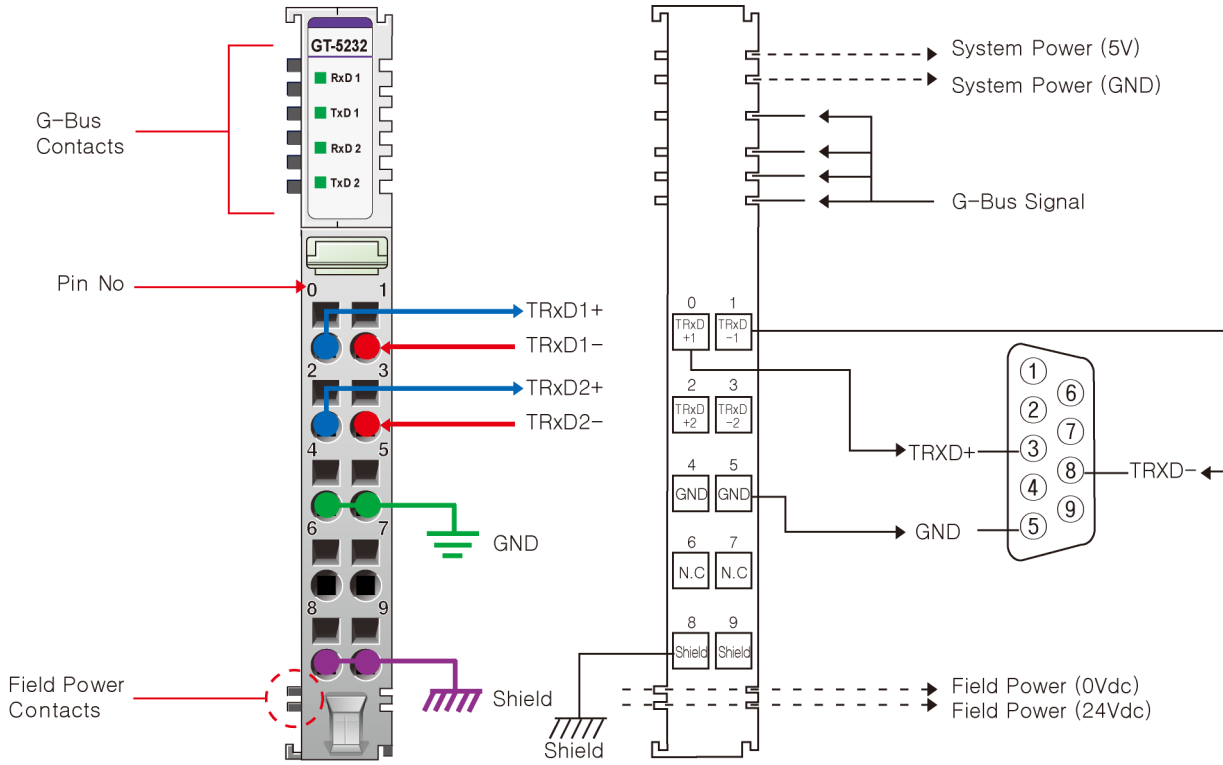

Pin No.	Signal Description	Signal Description	Pin No.
0	RS485+(ch0)	RS485-(ch0)	1
2	RS485+(ch1)	RS485-(ch1)	3
4	Common(GND)	Common(GND)	5
6	N.C	N.C	7
8	Shield	Shield	9

2.11. GT-5232 LED Indicator

2.11.1. LED Indicator



LED No.	LED Function / Description	LED Color
RxD1	Received Data 0	Green
TxD1	Transmit Data 0	Green
RxD2	Received Data 1	Green
TxD2	Transmit Data 1	Green

2.11.2. Channel Status LED

LED	Color	Status
RxD1	GREEN	Received Data 0
TxD1	GREEN	Transmit Data 0
RxD2	GREEN	Received Data 1
TxD2	GREEN	Transmit Data 1

2.12. Configuration and Operation Function

2.12.1. GT-52xx(Series) Mapping data into the image table

- **Input image data**

	bit#7	bit#6	bit#5	bit#4	bit#3	bit#2	bit#1	bit#0
Status	TPA	FTA	FRA	RE	RBO	RR	TA	IA

- **IA** : Initialization Acknowledge
- **TA** : Transmit Acknowledge
- **RR** : Receive Request
- **RBO** : RxD Buffer Overrun
- **RE** : RxD Exist (Remained)
- **FRA** : Flush RxD buffer Acknowledge
- **FTA** : Flush TxD buffer Acknowledge
- **TPA** : Transmit Processing Acknowledge

- **Output image data**

	bit#7	bit#6	bit#5	bit#4	bit#3	bit#2	bit#1	bit#0
Control	TPR	FT	FR	----	----	RA	TR	IR

- **IR** : Initialization Request (rising edge active)
- **TR** : Transmit Request (both edge active)
- **RA** : Receive Acknowledge (both edge active)
- **FR** : Flush RxD buffer Request (rising edge active)
- **FT** : Flush TxD buffer Request (rising edge active)
- **TPR** : Transmit Processing Request (both edge active)

Specification

- **GT-5211,5221,5231_image data (Input, Output Data Size : Default, 16Byte)**

IO Input		IO Output	
Byte#0	Status	Byte#0	Control
Byte#1	RxLength	Byte#1	TxLength
Byte#2	RxData#0	Byte#2	TxData#0
Byte#3	RxData#1	Byte#3	TxData#1
Byte#4	RxData#2	Byte#4	TxData#2
Byte#5	RxData#3	Byte#5	TxData#3
Byte#6	RxData#4	Byte#6	TxData#4
Byte#7	RxData#5	Byte#7	TxData#5
Byte#8	RxData#6	Byte#8	TxData#6
Byte#9	RxData#7	Byte#9	TxData#7
Byte#10	RxData#8	Byte#10	TxData#8
Byte#11	RxData#9	Byte#11	TxData#9
Byte#12	RxData#10	Byte#12	TxData#10
Byte#13	RxData#11	Byte#13	TxData#11
Byte#14	RxData#12	Byte#14	TxData#12
Byte#15	RxData#13	Byte#15	TxData#13
-----	-----	-----	-----
-----	-----	-----	-----
-----	-----	-----	-----
-----	-----	-----	-----
Byte#62	RxData#60	Byte#62	TxData#60

- The input and output data size can be changed via parameter data.

(IO data size **MAX 63Byte**)

- **Default** Input, output data size : 16Byte

Specification

- **GT-5212,5232_image data (Input, Output Data Size : Default, 16Byte)**

IO Input		IO Output	
Byte#0	Ch#0 Status	Byte#0	Ch#0 Control
Byte#1	Ch#0 RxLength	Byte#1	Ch#0 TxLength
Byte#2	Ch#0 RxData#0	Byte#2	Ch#0 TxData#0
Byte#3	Ch#0 RxData#1	Byte#3	Ch#0 TxData#1
Byte#4	Ch#0 RxData#2	Byte#4	Ch#0 TxData#2
Byte#5	Ch#0 RxData#3	Byte#5	Ch#0 TxData#3
Byte#6	Ch#0 RxData#4	Byte#6	Ch#0 TxData#4
Byte#7	Ch#0 RxData#5	Byte#7	Ch#0 TxData#5
Byte#8	Ch#1 Status	Byte#8	Ch#1 Control
Byte#9	Ch#1 RxLength	Byte#9	Ch#1 TxLength
Byte#10	Ch#1 RxData#0	Byte#10	Ch#1 TxData#0
Byte#11	Ch#1 RxData#1	Byte#11	Ch#1 TxData#1
Byte#12	Ch#1 RxData#2	Byte#12	Ch#1 TxData#2
Byte#13	Ch#1 RxData#3	Byte#13	Ch#1 TxData#3
Byte#14	Ch#1 RxData#4	Byte#14	Ch#1 TxData#4
Byte#15	Ch#1 RxData#5	Byte#15	Ch#1TxData#5

- **1 channel** Input, output data size : 8Byte
- **Default** Input, output data All size : 16Byte
- The input and output data size can be changed via parameter data.
(IO data size **MAX 62Byte**)
- Can be set IO data size Even number
(If set to an odd number IO data size, Automatically changes to an even number)

2.13. Configuration Parameter Data

- Precautions for use : if you changed Parameter, you must reset Module

2.13.1. 1 Chnnel Module Parameter Data(GT-5211)

	Bit#7	Bit#6	Bit#5	Bit#4	Bit#3	Bit#2	Bit#1	Bit#0
Byte#0	* Note 1	Stop bit	Parity Bit		Baudrate			
	TxD Process	0 : 1bit	00 : No		0000 : 115200bps			
	0 : Disable	1 : 2bit	01 : Odd		0001 : 1200bps			
	1 : Enable		10 : Even		0010 : 2400bps			
					0011 : 4800bps			
					0100 : 9600bps			
					0101 : 19200bps			
					0110 : 38400bps			
					0111 : 57600bps			
					1000 : 115200bps			
				Others : 115200bps				
Byte#1	Bit#7	Bit#6	Bit#5	Bit#4	Bit#3	Bit#2	Bit#1	Bit#0
	IO data size						Flow Control	
	16~63						00 : RTS/CTS Disable	
							01 : RTS Enable	
							10 : CTS Enable	
						11 : RTS/CTS Enable		
Byte#2	Bit#7	Bit#6	Bit#5	Bit#4	Bit#3	Bit#2	Bit#1	Bit#0
	Not Used							
Byte#3	Bit#7	Bit#6	Bit#5	Bit#4	Bit#3	Bit#2	Bit#1	Bit#0
	Not Used							

- byte#0~1 for ch#0, byte#2~3 not used

*** Note 1:**

- Disable : Transmit immediately Output data
- Enable : Store the value of Output Data continually at TxD Buffer of Serial Interface Module, when TPA bit and TPR bit of Control Byte and Status Byte are different, transmit all Data that saved at TxD Buffer

Specification

2.13.2. 1 Chnnel Module Parameter Data(GT-5221, 5231)

	Bit#7	Bit#6	Bit#5	Bit#4	Bit#3	Bit#2	Bit#1	Bit#0
Byte#0	* Note 1		Stop bit	Parity Bit	Baudrate			
	TxD Process	0 : 1bit	00 : No		0000 : 115200bps			
	0 : Disable	1 : 2bit	01 : Odd		0001 : 1200bps			
	1 : Enable		10 : Even		0010 : 2400bps			
					0011 : 4800bps			
					0100 : 9600bps			
					0101 : 19200bps			
					0110 : 38400bps			
					0111 : 57600bps			
					1000 : 115200bps			
				Others : 115200bps				
Byte#1	Bit#7	Bit#6	Bit#5	Bit#4	Bit#3	Bit#2	Bit#1	Bit#0
			IO data size					
			16~63					
Byte#2	Bit#7	Bit#6	Bit#5	Bit#4	Bit#3	Bit#2	Bit#1	Bit#0
	Not Used							
Byte#3	Bit#7	Bit#6	Bit#5	Bit#4	Bit#3	Bit#2	Bit#1	Bit#0
	Not Used							

- byte#0~1 for ch#0, byte#2~3 not used

*** Note 1:**

- Disable : Transmit immediately Output data
- Enable : Store the value of Output Data continually at TxD Buffer of Serial Interface Module, when TPA bit and TPR bit of Control Byte and Status Byte are different, transmit all Data that saved at TxD Buffer

Specification

2.13.3. 2 Chnnels Module Parameter Data(GT-5212, 5232)

	Bit#7	Bit#6	Bit#5	Bit#4	Bit#3	Bit#2	Bit#1	Bit#0
Byte#0	* Note 1	Stop bit	Parity Bit		Baudrate			
	TxD Process	0 : 1bit	00 : No		0000 : 115200bps			
	0 : Disable	1 : 2bit	01 : Odd		0001 : 1200bps			
	1 : Enable		10 : Even		0010 : 2400bps			
					0011 : 4800bps			
					0100 : 9600bps			
					0101 : 19200bps			
					0110 : 38400bps			
					0111 : 57600bps			
					1000 : 115200bps			
				Others : 115200bps				
Byte#1	Bit#7	Bit#6	Bit#5	Bit#4	Bit#3	Bit#2	Bit#1	Bit#0
			IO data size					
			16~62					
Byte#2	* Note 1	Stop bit	Parity Bit		Baudrate			
	TxD Process	0 : 1bit	00 : No		0000 : 115200bps			
	0 : Disable	1 : 2bit	01 : Odd		0001 : 1200bps			
	1 : Enable		10 : Even		0010 : 2400bps			
					0011 : 4800bps			
					0100 : 9600bps			
					0101 : 19200bps			
					0110 : 38400bps			
					0111 : 57600bps			
					1000 : 115200bps			
				Others : 115200bps				
Byte#3	Bit#7	Bit#6	Bit#5	Bit#4	Bit#3	Bit#2	Bit#1	Bit#0
	Not Used							

- byte#0~1 for ch#0, byte#2~3 for ch#1

*** Note 1:**

- Disable : Transmit immediately Output data
- Enable : Store the value of Output Data continually at TxD Buffer of Serial Interface Module, when TPA bit and TPR bit of Control Byte and Status Byte are different, transmit all Data that saved at TxD Buffer

2.14. Example

2.14.1. Example of Transmitting data

- Transmit data : A, B, C, D, E, F, G, H, I, J, K, L, M, N, O, P, Q, R, S, T, U, V, W, X, Y, Z(26byte)
- Input, Output data Size : 16byte
- Configuration Parameter

Parameter	Description	Value
Data Bit	8 Data Bit	Not used
Parity Bit	No Parity	Default Value
Baud rate	115200bps	Default Value
Stop Bit	1 Bit	Default Value
RTS/CTS Flow Control	RTS/CTS Disable	Default Value
TxD Process	Disable	Default Value

- Step#0

TR inverting (TR≠TA)

Output Length = 14byte (0x0E)

Output Data = "A, B, C, D, E, F, G, H, I, J, K, L, M, N"

	bit#7	bit#6	bit#5	bit#4	bit#3	bit#2	bit#1	bit#0
Status Byte #0	TPA	FTA	FRA	RE	RBO	RR	TA	IA
	0	0	0	0	0	0	0	0

	bit#7	bit#6	bit#5	bit#4	bit#3	bit#2	bit#1	bit#0
Control Byte #0	TPR	FT	FR	----	----	RA	TR	IR
	0	0	0	0	0	0	1	0
Tx Length #1	'0E'(14byte)							
Output Byte #2	'A' (0x41:ASCII code)							
Output Byte #3	'B' (0x42)							
Output Byte #4	'C' (0x43)							
Output Byte #5	'D' (0x44)							
Output Byte #6	'E' (0x45)							
Output Byte #7	'F' (0x46)							
Output Byte #8	'G' (0x47)							
Output Byte #9	'H' (0x48)							
Output Byte #10	'I' (0x49)							
Output Byte #11	'J' (0x4A)							
Output Byte #12	'K' (0x4B)							
Output Byte #13	'L' (0x4C)							
Output Byte #14	'M' (0x4D)							
Output Byte #15	'N' (0x4E)							

Specification

- Step#1

Check TA bit value in Status Byte.

TR=TA: transmit complete.

	bit#7	bit#6	bit#5	bit#4	bit#3	bit#2	bit#1	bit#0
Status Byte #0	TPA	FTA	FRA	RE	RBO	RR	TA	IA
	0	0	0	0	0	0	1	0

- Step#2

TR inverting (TR≠TA)

Output Length = 12byte (0x0C)

Output Data = "O, P, Q, R, S, T, U, V, W, X, Y, Z"

	bit#7	bit#6	bit#5	bit#4	bit#3	bit#2	bit#1	bit#0
Control Byte #0	TPR	FT	FR	----	----	RA	TR	IR
	0	0	0	0	0	0	0	0
Tx Length #1	'0C'(12byte)							
Output Byte #2	'O' (0x4F:ASCII code)							
Output Byte #3	'P' (0x50)							
Output Byte #4	'Q' (0x51)							
Output Byte #5	'R' (0x52)							
Output Byte #6	'S' (0x53)							
Output Byte #7	'T' (0x54)							
Output Byte #8	'U' (0x55)							
Output Byte #9	'V' (0x56)							
Output Byte #10	'W' (0x57)							
Output Byte #11	'X' (0x58)							
Output Byte #12	'Y' (0x59)							
Output Byte #13	'Z' (0x5A)							
Output Byte #14	0x00							
Output Byte #15	0x00							

- Step#3

Check TA bit value in Status Byte.

TR=TA: transmit complete.

	bit#7	bit#6	bit#5	bit#4	bit#3	bit#2	bit#1	bit#0
Status Byte #0	TPA	FTA	FRA	RE	RBO	RR	TA	IA
	0	0	0	0	0	0	0	0

Specification

2.14.2. Example of Receiving data

- Receive data : “ Company:CREVIS G-Series“(22byte)
- Input, Output data Size : 16byte
- Configuration Parameter

Parameter	Description	Value
Data Bit	8 Data Bit	Not used
Parity Bit	No Parity	Default Value
Baud rate	115200bps	Default Value
Stop Bit	1 Bit	Default Value
RTS/CTS Flow Control	RTS/CTS Disable	Default Value
TxD Process	Disable	Default Value

- Step#0

RR=RA

RE : RxD Exist (Remained)

	bit#7	bit#6	bit#5	bit#4	bit#3	bit#2	bit#1	bit#0
Status Byte #0	TPA	FTA	FRA	RE	RBO	RR	TA	IA
	0	0	0	1	0	0	0	0

	bit#7	bit#6	bit#5	bit#4	bit#3	bit#2	bit#1	bit#0
Control Byte #0	TPR	FT	FR	----	----	RA	TR	IR
	0	0	0	0	0	0	0	0

- Step#1

RA inverting (RA≠RR)

	bit#7	bit#6	bit#5	bit#4	bit#3	bit#2	bit#1	bit#0
Control Byte #0	TPR	FT	FR	----	----	RA	TR	IR
	0	0	0	0	0	1	0	0

Specification

- Step#2

Check RR bit value in Status Byte

RA=RR : receive complete

Input Length = 14byte

Input Data = “Company:CREVIS”

	bit#7	bit#6	bit#5	bit#4	bit#3	bit#2	bit#1	bit#0
Status Byte #0	TPA	FTA	FRA	RE	RBO	RR	TA	IA
	0	0	0	1	0	1	0	0
RX Length #1	‘0E’(14byte)							
Input Byte #2	‘C’ (0x43:ASCII code)							
Input Byte #3	‘o’ (0x6F)							
Input Byte #4	‘m’ (0x6D)							
Input Byte #5	‘p’ (0x70)							
Input Byte #6	‘a’ (0x61)							
Input Byte #7	‘n’ (0x6E)							
Input Byte #8	‘y’ (0x79)							
Input Byte #9	‘.’ (0x3A)							
Input Byte #10	‘C’ (0x43)							
Input Byte #11	‘R’ (0x52)							
Input Byte #12	‘E’ (0x45)							
Input Byte #13	‘V’ (0x56)							
Input Byte #14	‘I’ (0x49)							
Input Byte #15	‘S’ (0x53)							

- Step#3

RA inverting (RA≠RR)

	bit#7	bit#6	bit#5	bit#4	bit#3	bit#2	bit#1	bit#0
Control Byte #0	TPR	FT	FR	----	----	RA	TR	IR
	0	0	0	0	0	0	0	0

Specification

- Step#4

Check RR bit value in Status Byte

RA=RR : receive complete

Input Length = 8byte

Input Data = "G-Series"

	bit#7	bit#6	bit#5	bit#4	bit#3	bit#2	bit#1	bit#0
Status Byte #0	TPA	FTA	FRA	RE	RBO	RR	TA	IA
	0	0	0	0	0	0	0	0
RX Length #1	' 08'(8byte)							
Input Byte #2	'G' (0x47:ASCII code)							
Input Byte #3	'-' (0x2D)							
Input Byte #4	'S' (0x53)							
Input Byte #5	'e' (0x65)							
Input Byte #6	'r' (0x72)							
Input Byte #7	'i' (0x69)							
Input Byte #8	'e' (0x65)							
Input Byte #9	's' (0x73)							
Input Byte #10	0x00							
Input Byte #11	0x00							
Input Byte #12	0x00							
Input Byte #13	0x00							
Input Byte #14	0x00							
Input Byte #15	0x00							

Specification

2.14.3. Example of Transmitting data and Receiving data

- Transmit data: "CREVIS"(6byte) _Receive data : "CREVIS"(6byte)
- Input, Output data Size : 16byte
- Configuration Parameter

Parameter	Description	Value
Data Bit	8 Data Bit	Not used
Parity Bit	No Parity	Default Value
Baud rate	115200bps	Default Value
Stop Bit	1 Bit	Default Value
RTS/CTS Flow Control	RTS/CTS Disable	Default Value
TxD Process	Disable	Default Value

- Step#0 (Transmit)

TR inverting (TR≠TA)

Output Length = 6byte

Output Data = "CREVIS"

	bit#7	bit#6	bit#5	bit#4	bit#3	bit#2	bit#1	bit#0
Control Byte #0	TPR	FT	FR	----	----	RA	TR	IR
	0	0	0	0	0	0	1	0
Tx Length #1	‘ 06’(6byte)							
Output Byte #2	‘C’ (0x43:ASCII code)							
Output Byte #3	‘R’ (0x52)							
Output Byte #4	‘E’ (0x45)							
Output Byte #5	‘V’ (0x56)							
Output Byte #6	‘I’ (0x49)							
Output Byte #7	‘S’ (0x53)							
Output Byte #8	0x00							
Output Byte #9	0x00							
Output Byte #10	0x00							
Output Byte #11	0x00							
Output Byte #12	0x00							
Output Byte #13	0x00							
Output Byte #14	0x00							
Output Byte #15	0x00							

Specification

- Step#1

Check TA bit value in Status Byte.

TR=TA: transmit complete.

	bit#7	bit#6	bit#5	bit#4	bit#3	bit#2	bit#1	bit#0
Status Byte #0	TPA	FTA	FRA	RE	RBO	RR	TA	IA
	0	0	0	0	0	0	1	0

- Step#2 (Receive)

RR=RA

RE : RxD Exist (Remained)

	bit#7	bit#6	bit#5	bit#4	bit#3	bit#2	bit#1	bit#0
Status Byte #0	TPA	FTA	FRA	RE	RBO	RR	TA	IA
	0	0	0	1	0	0	0	0

	bit#7	bit#6	bit#5	bit#4	bit#3	bit#2	bit#1	bit#0
Control Byte #0	TPR	FT	FR	----	----	RA	TR	IR
	0	0	0	0	0	0	0	0

- Step#3

RA inverting (RA≠RR)

	bit#7	bit#6	bit#5	bit#4	bit#3	bit#2	bit#1	bit#0
Control Byte #0	TPR	FT	FR	----	----	RA	TR	IR
	0	0	0	0	0	1	0	0

Specification

- Step#4

Check RR bit value in Status Byte

RA=RR : receive complete

Input Length = 6byte

Input Data = "CREVIS"

	bit#7	bit#6	bit#5	bit#4	bit#3	bit#2	bit#1	bit#0
Status Byte #0	TPA	FTA	FRA	RE	RBO	RR	TA	IA
	0	0	0	0	0	1	0	0
RX Length #1	'06'(6byte)							
Input Byte #2	'C' (0x43:ASCII code)							
Input Byte #3	'R' (0x52)							
Input Byte #4	'E' (0x45)							
Input Byte #5	'V' (0x56)							
Input Byte #6	'I' (0x49)							
Input Byte #7	'S' (0x53)							
Input Byte #8	0x00							
Input Byte #9	0x00							
Input Byte #10	0x00							
Input Byte #11	0x00							
Input Byte #12	0x00							
Input Byte #13	0x00							
Input Byte #14	0x00							
Input Byte #15	0x00							

Specification

2.14.4. TPR and TPA Example

- Transmit data: "CREVIS"(6byte)
- Input, Output data Size : 16byte
- Configuration Parameter

Parameter	Description	Value
Data Bit	8 Data Bit	Not used
Parity Bit	No Parity	Default Value
Baud rate	115200bps	Default Value
Stop Bit	1 Bit	Default Value
RTS/CTS Flow Control	RTS/CTS Disable	Default Value
TxD Process	Enable	Default Value(Disable)

- Step#0

TxD Process data in Configuration Parameter set to "1" (Enable)

- Step#1

TR inverting (TR≠TA)

Output Length = 3

Output Data = "CRE"02

	bit#7	bit#6	bit#5	bit#4	bit#3	bit#2	bit#1	bit#0
Status Byte #0	TPA	FTA	FRA	RE	RBO	RR	TA	IA
	0	0	0	0	0	0	0	0
	bit#7	bit#6	bit#5	bit#4	bit#3	bit#2	bit#1	bit#0
Control Byte #0	TPR	FT	FR	----	----	RA	TR	IR
	0	0	0	0	0	0	1	0
Tx Length #1	' 03'(3byte)							
Output Byte #2	'C' (0x43:ASCII code)							
Output Byte #3	'R' (0x52)							
Output Byte #4	'E' (0x45)							
Output Byte #5	0x00							
Output Byte #6	0x00							
Output Byte #7	0x00							
Output Byte #8	0x00							
Output Byte #9	0x00							
Output Byte #10	0x00							
Output Byte #11	0x00							
Output Byte #12	0x00							
Output Byte #13	0x00							
Output Byte #14	0x00							
Output Byte #15	0x00							

Specification

- Step#2

Check TA bit value in Status Byte.

TR=TA: transmit complete.

	bit#7	bit#6	bit#5	bit#4	bit#3	bit#2	bit#1	bit#0
Status Byte #0	TPA	FTA	FRA	RE	RBO	RR	TA	IA
	0	0	0	0	0	0	1	0

TxD Buffer

Offset	TxD Buffer Data
Output Byte #0	'C' (0x43:ASCII code)
Output Byte #1	'R' (0x52)
Output Byte #2	'E' (0x45)
Output Byte #3	0x00
Output Byte #4	0x00
Output Byte #5	0x00
Output Byte #6	0x00
Output Byte #7	0x00
Output Byte #8	0x00
.	.
.	.
.	.
.	.
.	.
Output Byte #252	0x00
Output Byte #253	0x00
Output Byte #254	0x00
Output Byte #255	0x00

Specification

- Step#3

TR inverting (TR≠TA)

Output Length = 3

Output Data = “VIS”

	bit#7	bit#6	bit#5	bit#4	bit#3	bit#2	bit#1	bit#0
Control Byte #0	TPR	FT	FR	----	----	RA	TR	IR
	0	0	0	0	0	0	0	0
Tx Length #1	‘03’(3byte)							
Output Byte #2	‘V’ (0x56 ASCII code)							
Output Byte #3	‘I’ (0x49)							
Output Byte #4	‘S’ (0x53)							
Output Byte #5	0x00							
Output Byte #6	0x00							
Output Byte #7	0x00							
Output Byte #8	0x00							
Output Byte #9	0x00							
Output Byte #10	0x00							
Output Byte #11	0x00							
Output Byte #12	0x00							
Output Byte #13	0x00							
Output Byte #14	0x00							
Output Byte #15	0x00							

- Step#4

Check TA bit value in Status Byte.

TR=TA: transmit complete

	bit#7	bit#6	bit#5	bit#4	bit#3	bit#2	bit#1	bit#0
Status Byte #0	TPA	FTA	FRA	RE	RBO	RR	TA	IA
	0	0	0	0	0	0	0	0

Specification

TxD Buffer

Offset	TxD Buffer Data
Output Byte #0	'C' (0x43:ASCII code)
Output Byte #1	'R' (0x52)
Output Byte #2	'E' (0x45)
Output Byte #3	'V' (0x56 ASCII code)
Output Byte #4	'I' (0x49)
Output Byte #5	'S' (0x53)
Output Byte #6	0x00
Output Byte #7	0x00
Output Byte #8	0x00
.	.
.	.
.	.
.	.
.	.
Output Byte #252	0x00
Output Byte #253	0x00
Output Byte #254	0x00
Output Byte #255	0x00

- Step#5

TPR inverting (TPR≠TPA)

	bit#7	bit#6	bit#5	bit#4	bit#3	bit#2	bit#1	bit#0
Control Byte #0	TPR	FT	FR	----	----	RA	TR	IR
	1	0	0	0	0	1	0	0

Specification

Transmit all TxD Buffer data (TxD Buffer empty)

Offset	TxD Buffer Data
Output Byte #0	0x00
Output Byte #1	0x00
Output Byte #2	0x00
Output Byte #3	0x00
Output Byte #4	0x00
Output Byte #5	0x00
Output Byte #6	0x00
Output Byte #7	0x00
Output Byte #8	0x00
.	.
.	.
.	.
.	.
.	.
Output Byte #252	0x00
Output Byte #253	0x00
Output Byte #254	0x00
Output Byte #255	0x00

- Step#6

Check TPA bit value in Status Byte.

TPR=TPA: transmit complete

	bit#7	bit#6	bit#5	bit#4	bit#3	bit#2	bit#1	bit#0
Status Byte #0	TPA	FTA	FRA	RE	RBO	RR	TA	IA
	1	0	0	0	0	0	0	0

Specification

2.14.5. GT-5211, 5221(1ch) RxD Buffer data Overrun Check

For example, if other device transmits 1025 bytes of TxD data, RxD buffer of GT-52xx (Serial) will be overwritten 1 bytes.

Other device		GT-52xx(Serial)	
Offset	TxD Data	Offset	RxD Buffer data
Output Byte #1	0x01	Input Byte #1	0x06(Overrun data)
Output Byte #2	0x02	Input Byte #2	0x02
Output Byte #3	0x03	Input Byte #3	0x03
Output Byte #4	0x04	Input Byte #4	0x04
Output Byte #5	0x05	Input Byte #5	0x05
Output Byte #6	0x06	Input Byte #6	0x06
.	.	.	
.	.	.	
.	.	.	
Output Byte #1020	0x01	Input Byte #1019	0x10
Output Byte #1021	0x02	Input Byte #1020	0x01
Output Byte #1022	0x03	Input Byte #1021	0x02
Output Byte #1023	0x04	Input Byte #1022	0x03
Output Byte #1024 MAX	0x05	Input Byte #1023	0x04
Output Byte #1025	0x06(Overrun data)	Input Byte #1024	0x05

RE (RxD Exist) bit check

	bit#7	bit#6	bit#5	bit#4	bit#3	bit#2	bit#1	bit#0
Status Byte #0	TPA	FTA	FRA	RE	RBO	RR	TA	IA
	0	0	0	1	0	0	0	0

RA (Receive Acknowledge) bit set

	bit#7	bit#6	bit#5	bit#4	bit#3	bit#2	bit#1	bit#0
Control Byte #0	TPR	FT	FR	----	----	RA	TR	IR
	0	0	0	0	0	1	0	0

PLEASE CHECK RBO bit in Status Byte in order to prevent overwrite RX buffer.

When the RBO bit is set, it notifies that the RX buffer is full.

	bit#7	bit#6	bit#5	bit#4	bit#3	bit#2	bit#1	bit#0
Status Byte #0	TPA	FTA	FRA	RE	RBO	RR	TA	IA
	0	0	0	1	1	1	0	0

Specification

If you try to write more than 1024 bytes on RX buffer, 1025rd byte overwrites the first byte on RX buffer.

Thus, it is recommended to write less than 1024 bytes.

IR (Initialization Request) bit set

	bit#7	bit#6	bit#5	bit#4	bit#3	bit#2	bit#1	bit#0
Control Byte #0	TPR	FT	FR	----	----	RA	TR	IR
	0	0	0	0	0	0	0	1

RxD Buffer data Reset.

Offset	RxD Buffer Data
Input Byte #1	0x00
Input Byte #2	0x00
Input Byte #3	0x00
Input Byte #4	0x00
Input Byte #5	0x00
Input Byte #6	0x00
.	.
.	.
.	.
Input Byte #1021	0x00
Input Byte #1022	0x00
Input Byte #1023	0x00
Input Byte #1024	0x00

2.14.6. How to change I/O Data Size in XML file(I/O Guide Pro)

- 1ch Module XML Change location

```

<IOData InputLength="16" OutputLength="16">
  <Input OneChSize="8">
    <Ref TextId="T_Status_Data_00" ChannelType="BI" DataType="ByteArea" Length="1" Unit="" Visible="true"/>
    <Ref TextId="T_Length_Data_00" ChannelType="BI" DataType="ByteArea" Length="1" Unit="" Visible="true"/>
    <Ref TextId="T_Byte_InData_00" ChannelType="BI" DataType="ByteArea" Length="1" Unit="" Visible="true"/>
    <Ref TextId="T_Byte_InData_01" ChannelType="BI" DataType="ByteArea" Length="1" Unit="" Visible="true"/>
    <Ref TextId="T_Byte_InData_02" ChannelType="BI" DataType="ByteArea" Length="1" Unit="" Visible="true"/>
    <Ref TextId="T_Byte_InData_03" ChannelType="BI" DataType="ByteArea" Length="1" Unit="" Visible="true"/>
    <Ref TextId="T_Byte_InData_04" ChannelType="BI" DataType="ByteArea" Length="1" Unit="" Visible="true"/>
    <Ref TextId="T_Byte_InData_05" ChannelType="BI" DataType="ByteArea" Length="1" Unit="" Visible="true"/>
    <Ref TextId="T_Byte_InData_06" ChannelType="BI" DataType="ByteArea" Length="1" Unit="" Visible="true"/>
    <Ref TextId="T_Byte_InData_07" ChannelType="BI" DataType="ByteArea" Length="1" Unit="" Visible="true"/>
    <Ref TextId="T_Byte_InData_08" ChannelType="BI" DataType="ByteArea" Length="1" Unit="" Visible="true"/>
    <Ref TextId="T_Byte_InData_09" ChannelType="BI" DataType="ByteArea" Length="1" Unit="" Visible="true"/>
    <Ref TextId="T_Byte_InData_10" ChannelType="BI" DataType="ByteArea" Length="1" Unit="" Visible="true"/>
    <Ref TextId="T_Byte_InData_11" ChannelType="BI" DataType="ByteArea" Length="1" Unit="" Visible="true"/>
    <Ref TextId="T_Byte_InData_12" ChannelType="BI" DataType="ByteArea" Length="1" Unit="" Visible="true"/>
    <Ref TextId="T_Byte_InData_13" ChannelType="BI" DataType="ByteArea" Length="1" Unit="" Visible="true"/>
    Write <Ref TextId="T_Byte_InData_XX" ChannelType="BI" DataType="ByteArea" Length="1" Unit="" Visible="true"/>
  </Input>
  <Output OneChSize="8">
    <Ref TextId="T_Ctrl_Data_00" ChannelType="BO" DataType="ByteArea" Length="1" Unit="" Visible="true"/>
    <Ref TextId="T_Length_Data_00" ChannelType="BO" DataType="ByteArea" Length="1" Unit="" Visible="true"/>
    <Ref TextId="T_Byte_OutData_00" ChannelType="BO" DataType="ByteArea" Length="1" Unit="" Visible="true"/>
    <Ref TextId="T_Byte_OutData_01" ChannelType="BO" DataType="ByteArea" Length="1" Unit="" Visible="true"/>
    <Ref TextId="T_Byte_OutData_02" ChannelType="BO" DataType="ByteArea" Length="1" Unit="" Visible="true"/>
    <Ref TextId="T_Byte_OutData_03" ChannelType="BO" DataType="ByteArea" Length="1" Unit="" Visible="true"/>
    <Ref TextId="T_Byte_OutData_04" ChannelType="BO" DataType="ByteArea" Length="1" Unit="" Visible="true"/>
    <Ref TextId="T_Byte_OutData_05" ChannelType="BO" DataType="ByteArea" Length="1" Unit="" Visible="true"/>
    <Ref TextId="T_Byte_OutData_06" ChannelType="BO" DataType="ByteArea" Length="1" Unit="" Visible="true"/>
    <Ref TextId="T_Byte_OutData_07" ChannelType="BO" DataType="ByteArea" Length="1" Unit="" Visible="true"/>
    <Ref TextId="T_Byte_OutData_08" ChannelType="BO" DataType="ByteArea" Length="1" Unit="" Visible="true"/>
    <Ref TextId="T_Byte_OutData_09" ChannelType="BO" DataType="ByteArea" Length="1" Unit="" Visible="true"/>
    <Ref TextId="T_Byte_OutData_10" ChannelType="BO" DataType="ByteArea" Length="1" Unit="" Visible="true"/>
    <Ref TextId="T_Byte_OutData_11" ChannelType="BO" DataType="ByteArea" Length="1" Unit="" Visible="true"/>
    <Ref TextId="T_Byte_OutData_12" ChannelType="BO" DataType="ByteArea" Length="1" Unit="" Visible="true"/>
    <Ref TextId="T_Byte_OutData_13" ChannelType="BO" DataType="ByteArea" Length="1" Unit="" Visible="true"/>
    Write <Ref TextId="T_Byte_OutData_XX" ChannelType="BO" DataType="ByteArea" Length="1" Unit="" Visible="true"/>
  </Output>
</IOData>

```

Specification

- Step#1

```
<IOData InputLength="16" OutputLength="16">
```

Change InputLength, OutputLength

ex) I/O Data Size : 30Byte

```
< IOData InputLength="30" OutputLength="30">
```

-Step#2

Add T_Byte_InData_XX & T_Byte_OutData_XX

ex) I/O Data Size : 18Byte

Add the following to the Write area.

- 1ch Module

Input area

```
<Ref TextId="T_Byte_InData_14" ChannelType="BI" DataType="ByteArea" Length="1" Unit="" Visible="true"/>
```

```
<Ref TextId="T_Byte_InData_15" ChannelType="BI" DataType="ByteArea" Length="1" Unit="" Visible="true"/>
```

Output area

```
<Ref TextId="T_Byte_OutData_14" ChannelType="BO" DataType="ByteArea" Length="1" Unit="" Visible="true"/>
```

```
<Ref TextId="T_Byte_OutData_15" ChannelType="BO" DataType="ByteArea" Length="1" Unit="" Visible="true"/>
```

- 2ch Module

1ch Input area

```
<Ref TextId="T_Byte_InData_06" ChannelType="BI" DataType="ByteArea" Length="1" Unit="" Visible="true"/>
```

2ch Input area

```
<Ref TextId="T_Byte_InData_06" ChannelType="BI" DataType="ByteArea" Length="1" Unit="" Visible="true"/>
```

1ch Output area

```
<Ref TextId="T_Byte_OutData_06" ChannelType="BO" DataType="ByteArea" Length="1" Unit="" Visible="true"/>
```

2ch Output area

```
<Ref TextId="T_Byte_OutData_06" ChannelType="BO" DataType="ByteArea" Length="1" Unit="" Visible="true"/>
```

2.14.7. How to change I/O Data Size in XML file(CODESYS)

- XML Change location

```
<Parameter ParameterId="1000" type="localTypes:ARRAY [0..15] OF TBit1Byte">
  <Attributes channel="input" download="true" functional="false" offlineaccess="read" onlineaccess="read" />
  <Default>0</Default>
  <Name name="local:in0">IN</Name>
</Parameter>

<Parameter ParameterId="2000" type="localTypes:ARRAY [0..15] OF TBit1Byte">
  <Attributes channel="output" download="true" functional="false" offlineaccess="readwrite" onlineaccess="readwrite" />
  <Default>0</Default>
  <Name name="local:out0">OUT</Name>
</Parameter>
```

Change Array range

ex) I/O Data Size : 30Byte

[0..15] → [0..29]